

ATV ROBOTIC POOL CLEANER



Installation - Operation - Warranty Manual



This equipment is to be installed and serviced by a qualified technician. Improper installation may result in property damage, serious injury or death. Improper installation and/or operation will void the warranty.

Notice to Installer

This manual contains important information about the installation, operation & safe use of this product. Once the product has been sold or installed this manual must be given to the owner/operator of this equipment.

Table of Contents

Safety Information	2-3	Power Cord Maintenance	10
General Instructions	3	Storing The Power Cord	11
Floating Swivel Setup	4-5	General Maintenance	11
Installation	6-7	Winter Storage	11
RCD Operation	6	Warranty	12-15
Removing Cleaner from Pool	8-9	Trouble Shooting	16-17
Cleaning Filter Bags	8-9	Notes	18-19

CONGRATULATIONS

Congratulations and thank you for choosing our Waterco Admiral ATV Robotic Pool Cleaner the most technologically advanced automatic Robotic Pool Cleaner available. The Admiral ATV is equipped with "Fast Track Technology" that offers 2 cleaning options, a 1 hour "Fast" clean cycle and a 3 hour "Full" clean cycle. Selecting the 1 hour "Fast" cleaning cycle, the Admiral ATV will not climb the pool walls, but concentrate its cleaning cycle on the pool floor where the majority of debris is usually located. Selecting the 3 hour "Full" cleaning cycle the Admiral ATV not only cleans your pool's floor; it also climbs and scrubs your pool walls up to the water line.

We are sure you will find your new Admiral ATV a pleasure to use. Before you use the cleaner, we recommend that you read through the relevant sections of this manual, which provides a description of your cleaner and its functions.

To avoid the risks that are always present when you use a Robotic Pool Cleaner, it is important that the cleaner is installed correctly and that you read the safety instructions carefully to avoid misuse and hazards.

We recommend that you keep this instruction booklet for future reference and pass it on to any future owners.

After unpacking the Admiral ATV, please check it is not damaged. If in doubt, do not use the cleaner but contact the store that you purchased the cleaner.

WARNING

1. DO NOT RUN THE Admiral ATV OUT OF THE WATER. OPERATING THE CLEANER OUT OF THE WATER WILL DAMAGE THE MOTORS AND VOID THE WARRANTY
2. THE Admiral ATV SHOULD NOT BE CONNECTED TO A TIMING DEVICE AND LEFT CONTINUOUSLY WITHIN A POOL OR SPA.
3. DON'T USE EXTENSION CORDS OR ADAPTER PLUGS WITH Admiral ATV – AS THIS MAY AFFECT THE CLEANER'S PERFORMANCE AND EXPOSURE TO ELECTROCUTION (EXPOSURE TO PERSONAL INJURY OR DEATH).
4. DO NOT PLACE ANY PORTION OF THE CLEANER OR ITS COMPONENTS IN THE POOL PRIOR TO CONNECTING THE FLOATING SWIVEL.

SAFETY INFORMATION

1. Waterco's Admiral ATV Robotic Pool Cleaner is designed to work with water at a temperature greater than 13°C (55°F) and less than 45°C (113°F). The cleaner should never be operated outside of these temperatures or damage may occur.
2. The installation should be carried out in accordance to local safety standards and bylaws.
3. Any modification of the Admiral ATV requires the prior consent from Waterco. Original replacement parts and accessories authorised by the manufacturer ensure a high level of safety. Waterco assumes no liability for the damage and injuries caused by unauthorised replacement parts and accessories.

4. The user should make sure that the installation is carried out by qualified authorised persons and that these persons have first carefully read the following instructions.
5. The operating safety of the Admiral ATV is only guaranteed if the installation and operation instructions are correctly followed.
6. In the event of defective operation or fault, contact Waterco or its nearest authorised service agent.
7. To reduce the risk of injury, do not permit children to use this product.
8. Incorrectly installed equipment may fail, causing severe injury or property damage.
9. Chemical spills and fumes can weaken the Admiral ATV. Corrosion can cause the cleaner and other equipment to fail, resulting in severe injury or property damage. Do not store pool chemicals near your equipment.
10. Do not play with the Admiral ATV or power cable as potential entrapment of hair or body parts may result. The power cord can trip or entangle swimmers which could result in drowning.
11. Your Admiral ATV should not be used while people are swimming in the pool.

GENERAL INSTRUCTIONS

- Maximum Recommended Pool Size: 9m x 12m x 2.4m depth.
Minimum Recommended Pool Size: 3m x 3m.
- If ambient air temperature exceeds 46°C (115°F), protect the Admiral ATV's power supply from direct sunlight. However, ensure power supply has adequate ventilation.
- Do not connect the Admiral ATV's power supply (transformer) to AC power until installation has been completed.
- Do not use if unit is damaged in any way.
- Make sure the Admiral ATV is unplugged from its power supply before opening the unit or performing any other maintenance.
- To avoid damage to the power supply & power cord, never carry the power supply by the power cord or pull on the power cord to disconnect from an outlet. Disconnect by pulling the plug, itself, from the outlet.
- Do not pull power cord around sharp corners or edges.
- Do not operate with a damaged power cord or power supply.
- Before installing the Admiral ATV, understand the cleaner's coverage. The cleaner was not designed to automatically clean steps or to work under solar covers. It was also not designed to do an initial clean up for a new pool installation.
- The power supply must be at least 4m (12ft) from the pool's edge at all times!.
- It is recommended that you clean your Admiral ATV filter bag and check the impeller to make sure it is free and clear of debris after every use.
- Disconnect the power supply supply from the outlet when not in use.
- DO NOT switch the Admiral ATV to "ON" if it is not immersed in water. Operating the cleaner out of water may cause severe damage & will result in loss of warranty. Always remember to turn the power supply "OFF" and unplug it from the power outlet before removing the cleaner from the pool.

FLOATING SWIVEL SETUP

WARNING:

All power cord connections must be made prior to using this cleaner. Do not place the cleaner into a pool prior to reading the following instructions.

HOW DOES IT WORK:

The Floating Swivel is designed to prevent cable twisting and tangling by providing a free spinning power cord that is able to rotate 360° in both directions, while maintaining electrical continuity. The Floating Swivel will float on the surface of the water as the cleaner moves around the pool. As tension builds in the cable, the outer cylindrical section of the Floating Swivel will keep the float stable allowing the front section of the Floating Swivel to rotate, releasing the power cord tension that has been generated by the cleaner's movement (See Figure S1).

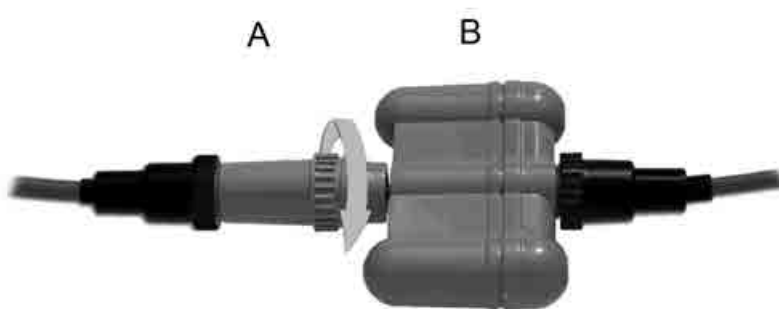

Figure S1

NOTE: The Floating Swivel performs most efficiently when floating on the surface of the pool water. If the depth of the pool exceeds the length of the provided cable (from cleaner to swivel, 2.4m) the Admiral ATV is not recommended for this pool

CONNECTING THE FLOATING SWIVEL:

The Float Swivel is not connected to the power cable inside the Admiral ATV carton. This is to prevent any unnecessary stress from being applied to the Floating Swivel and the connections during shipping. Following instructions are how to connect the Floating Swivel to the power cord.

The short power cord from cleaner to the Floating Swivel, 2.4m will need to be connected to the small end of the Floating Swivel (A). The long power cord from the Admiral ATV to the power supply, 15m will need to be connected to the large end of the Floating Swivel (B) as seen in Figure S1.

NOTE: The power cord connections are specifically designed to be different to prevent the wrong end of the power cord from being plugged into the wrong end of the Floating Swivel (See Figures S2 and S3).



Figure S2



Figure S3

IMPORTANT: DO NOT use any tools for the following steps. All power cord connections should be hand tightened.

1. Ensure the gasket is secured inside the black plug of the long cable (15m) as shown in Figure S4.

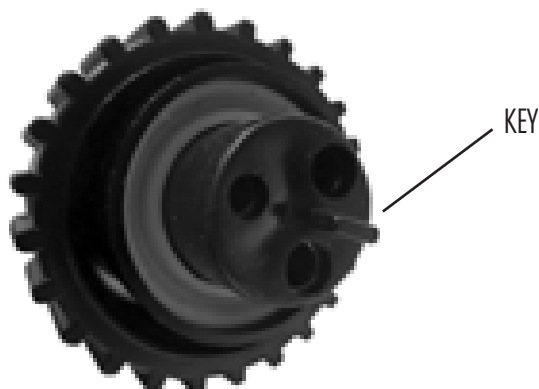

Figure S4

2. Insert the black plug on the end of the long cable (15m) into the large end of the Floating Swivel (B), as shown in Figure S5, ensuring the pins and key are aligned properly. Press power cord connections firmly together to ensure a proper connection is achieved.
3. Hold the swivel and hand tighten the black collar from the power cord to secure the connection (Figure S6A).
4. Insert the blue plug from the short power cable (from Admiral ATV to Floating Swivel, 2.4m) into the small end of the Floating Swivel (A) as shown in Figure S5, ensuring the gasket is in the Floating Swivel connector and the pins are properly aligned. Press firmly to ensure a solid connection is achieved.



Figure S5

5. Hold the swivel and hand tighten the black collar from the power cord to secure connection properly (Figure S6B).

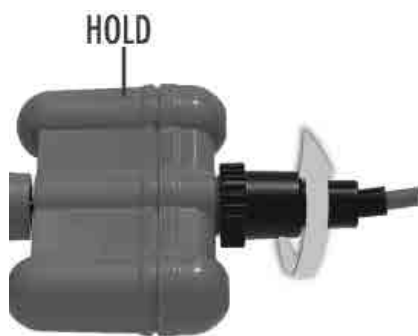

Figure S6A

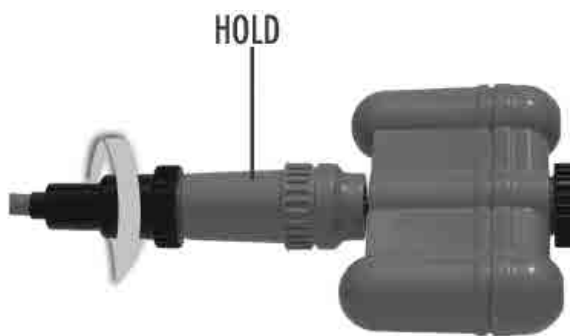

Figure S6B

6. Ensure that all power cord connections to the Floating Swivel are hand tightened properly prior to placing the Admiral ATV into the pool.

INSTALLATION

- Ensure power supply (transformer) is in the off position.
- The Admiral ATV is equipped with “Fast Track Technology” that offers 2 cleaning options, a 1 hour “Fast” clean cycle and a 3 hour “Full” clean cycle. Selecting the 1 hour “Fast” cleaning cycle, the Admiral ATV will not climb the pool walls, but concentrate its cleaning cycle on the pool floor where the majority of debris is usually located. Selecting the 3 hour “Full” cleaning cycle the Admiral ATV not only cleans your pool’s floor; it also climbs and scrubs your pool walls up to the water line.
- Plug the power supply lead into its own dedicated 220-240V, 50Hz AC electrical outlet. It is essential the power point is properly connected to an earth leakage circuit breaker and properly earthed to ground. Consult a qualified electrician if you are unsure.



IMPORTANT NOTE:

The cleaners power supply is also equipped with a Residual-Current Device (RCD). This device disconnects the power circuit whenever it detects that there is not a balance between the power and the return neutral conductor. Such an imbalance is sometimes caused by current leakage through the body of a person who is grounded and accidentally touching the powered part of the circuit and will prevent injury caused by such shocks. They are not intended to provide protection against overload or short circuit conditions, the earth leakage circuit breaker below will handle this situation.

WARNING:

It is strongly recommended that you test the RCD prior to using the cleaner power supply.

RCD OPERATION:

1. Plug power supply lead into dedicated electrical outlet.
2. Press RESET button and the indicator light should be on “Lite”.
3. Press TEST button and the indicator light should be on “Off”.
4. Press RESET button for use of the cleaner, do not use if TEST fails and indicator is on “Lite”.

- This RCD is not an overload protection device.
- This RCD device complies SAA AS/NZS3190, Approval No A/10643EA.
- Do not plug the power supply lead into an extension cord.
- Plug in the connector of the power cord from the cleaner into the power supply. The connector is keyed so that it will only plug into the power supply one way. Make sure that the plug is pushed all the way onto the power supply. Slide the connector lock (strain relief) onto the connector and turn the connector lock clockwise until it is tight (Do not over tighten).



WARNING:

1. DO NOT RUN THE CLEANER OUT OF THE WATER. OPERATING THE CLEANER OUT OF THE WATER WILL DAMAGE THE MOTORS AND VOID THE WARRANTY
2. THE Admiral ATV SHOULD NOT BE CONNECTED TO A TIMING DEVICE AND LEFT CONTINUOUSLY WITHIN A POOL OR SPA.
3. ENSURE ALL CONNECTIONS TO THE SWIVEL ARE SECURE PRIOR TO PLACING THE CLEANER IN THE POOL.

- Place the Admiral ATV into the pool and rock the cleaner side to side to release any trapped air. The cleaner will sink to the bottom of the pool.
- Place sufficient length of the power cord into the water that will enable the Admiral ATV to easily reach all areas of the pool. (It is recommended not to place ALL of the power cord into the pool unless required, and any excess power cord is secured, so that it is not pulled into the pool during the Admiral ATV cleaning cycle).
- Turn on power supply at dedicated 220-240V, 50Hz AC electrical outlet and switch power supply to the on position, and the Admiral ATV will begin its cleaning program.
- The Admiral ATV is equipped with "Fast Track Technology" that offers 2 cleaning options, a 1 hour "Fast" clean cycle and a 3 hour "Full" clean cycle, refer power supply & power supply switch Image A.
- To select "Fast Track Technology" 1 hour "Fast" clean cycle push the top section of the power supply switch. The section of the switch has a figure "1". A YELLOW LED will be lit to indicate the 1 hour "Fast" clean cycle has been selected. This cleaning cycle will automatically shut off after 1 hour, but the cleaning cycle can be stopped by pressing the centre of the power supply switch, refer Image A.
- To select 3 hour "Full" clean cycle push the bottom section of the power supply switch. The section of the switch has a figure "3". A RED LED will be lit to indicate the 3 hour "Full" clean cycle has been selected. The Admiral ATV will clean the pool floor; it also climbs and scrubs the pool walls up to the water line. This cleaning cycle will automatically shut off after 3 hours, but the cleaning cycle can be stopped by pressing the centre of the power supply switch, refer Image A.
- If a second cleaning is required or the Admiral ATV is accidentally shut off, you should wait one minute before switching the cleaner on again. The cleaner has an automatic lock out period to protect the electronic intelligent navigation devices.

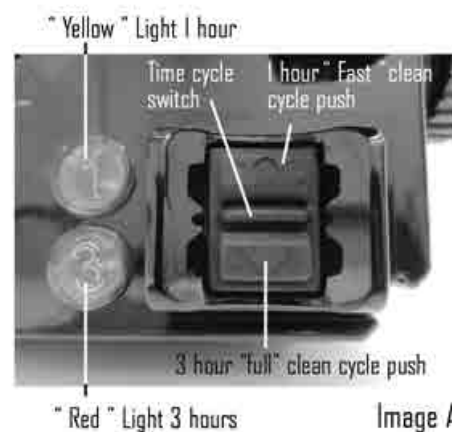

Image A



IMPORTANT NOTE:

During either "Fast Track Technology" 1 hour "Fast" or 3 hour "Full" cleaning cycles, the Admiral ATV may appear to shut off for a few seconds. This is a normal part of the pool cleaning program. The cleaner has multiple ways of cleaning the pool walls.

During the 1 hour "Fast" cleaning cycle, depending on the individual pool walls vertical angle the Admiral ATV may climb up the pools walls approximately 1 metre. This is a normal part of the Admiral ATV's operational program.

During the 3 hour "full" cleaning cycle the Admiral ATV may climb to the top of the pool wall, scrub, then make a turn and drive back down the pool wall to the bottom of the pool. It may also climb to the top of the pool wall, shut down for a few seconds, remove itself from the pool wall, turn its pump motor on again, pushing itself down to the bottom of the pool away from the wall.

Also, the Admiral ATV may climb the pool wall, scrub to the waterline, turn the pump motor off, and float away from the pool wall down to the bottom of the pool. All of these variations have been programmed into the cleaner and are designed to quickly and efficiently clean your entire pool. The Admiral ATV has also been designed to clean all areas of your pool. It will climb the pool walls, and occasionally break the pool water surface. In the process of climbing the pool walls it may stay on the pool water surface and continue to operate from several seconds to a few minutes. This is a normal operation procedure and the cleaner will eventually make its way to the bottom of the pool to continue its cleaning program. Generally, most of the dirt is concentrated on the floor of a pool the cleaner is designed to spend the majority of cleaning program on the pool floor.

REMOVING THE CLEANER FROM THE POOL

- Slowly pull the Admiral ATV's power cord to retrieve the cleaner to the water surface and pool edge. (DO NOT PULL THE CLEANER OUT OF THE POOL BY THE POWER CORD OR FLOATING SWIVEL).
- Reach down and grasp the handle of the Admiral ATV and remove it from the pool as shown in Fig 1 and Fig 2.

Note: The unit should be stored in an area that will afford some protection from the elements to insure that it retains its finish.

CLEANING THE ROBOTIC POOL CLEANER'S FILTER BAG

Note: It is strongly recommended that the Admiral ATV's filter bag should be cleaned after every use.

- Turn the Admiral ATV upside down and place on the ground or stable surface so the bottom lid is exposed.
- Locate the front and rear red retaining clips and unlock by turning as directed by the directional arrows as shown Figure 3.
- Press the two red tabs inward towards the centre of the Admiral ATV as shown in Figure 4. Lift the cleaner's bottom lid with the filter bag up and out of the cleaner.
- Grip the bottom lid of the Admiral ATV firmly, with one hand and use your other hand to grab the filter bag material and pull it away from and up from the bottom lid of the cleaner. Remove all large debris from the filter bag. Refer Figure 5.
- Turn filter bag inside out and hose out all remaining debris as shown in Figure 6. If filter bag is very dirty it may be washed in a washing machine.

Note: When using a washing machine it is recommended to turn the filter bag inside out and wash using cold water (only) and a mild detergent without any other item within the wash.

Note: Do NOT use a clothes dryer.

- Hose all debris out of the Admiral ATV's bottom lid being sure to remove all dirt from the fine filters situated on the intake doors as shown in Figure 7.
- To reinstall the Admiral ATV's filter bag, first place cleaner bottom lid facing up wards.
- Place the Admiral ATV's filter bag outer frame onto the cleaner bottom lid and ensure the filter bag frame seats fully into the retaining channels.

Note: Visually ensure the Admiral ATV's filter bag is correctly seated into cleaners bottom lid retaining channels particularly the corners. Refer Figure 8.

- Once the filter bag frame is correctly positioned into the Admiral ATV's bottom lid, retaining the filter bag is complete.
- Pick up the Admiral ATV's bottom lid and turn it over so the bag hangs down wards. Refit the cleaner's bottom lid back into the cleaner being careful to feed the cleaners filter bag back into the body of the cleaner.
- Once the Admiral ATV's bottom lid is seated press it firmly into the cleaner, the two red side tabs should click into place and turn the front and rear red retaining clips as indicated by the directional arrows into the locked position, refer Figure 9. Gently pull on the cleaner bottom lid to insure that it is properly locked in. The cleaner's bottom lid is now correctly installed.

Note: Ensure the Admiral ATV's filter bag is completely enclosed within the cleaner housing as the bottom lid will not close properly, and the cleaner will not operate.



Figure 1



Figure 2



Figure 3



Figure 4

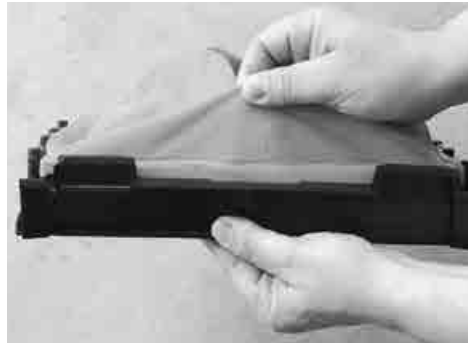

Figure 5

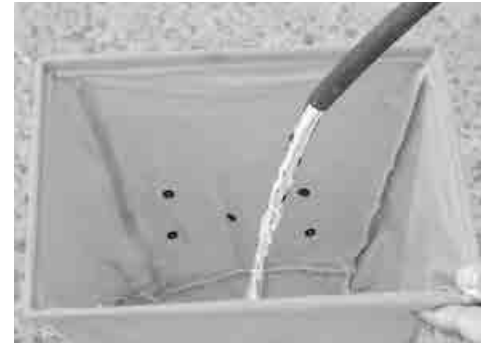

Figure 6



Figure 7



Figure 8



Figure 9

POWER CORD MAINTENANCE

In the course of using your Admiral ATV, the power cord may become twisted or tangled.

The Admiral ATV Power Kink Resistant Cord Advantage

The Admiral ATV Robotic Pool Cleaner has a specifically designed power kink resistant cord using its one piece extruded technology that prevents the cord from delaminating, protecting the internal wires from shorting out and extending its operating life.

If you refer to the power cord (Fig 10 below), there are no layers as the cable & wires are manufactured simultaneously. The coating of the cable is injected with air to form small pockets that allow it to float, so the outer layer takes the place of (3) layers of a typical cable.

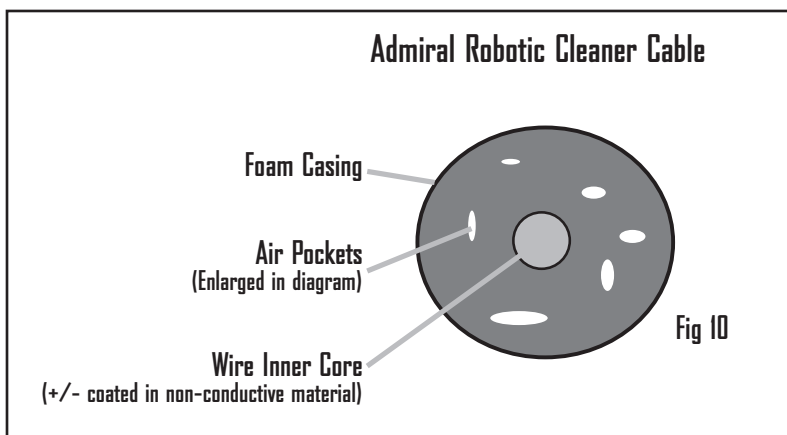

The Admiral ATV is equipped with the Floating Swivel to prevent power cord tangling, but the following five points can further prevent or greatly reduce tangling of the power cord:

- 1) Make sure there are no objects in the pool during the cleaning cycle for the power cord to get caught on (pool ropes, toys, etc).
- 2) Only allow enough power cord in the pool for full coverage/do not put excess power cord in the pool (Example 8m pool doesn't need 18m of power cord).
- 3) The Admiral ATV should not be connected to a timing device and left continuously within a pool or spa.
- 4) Remove the Admiral ATV from the pool and uncoil the power cord from the power supply after every cleaning cycle to release any tension in the power cord.
- 5) The Admiral ATV is designed to work with water at a temperatures greater than 13°C (55°F) and less than 45°C (113°F). The cleaner should never be operated outside of these temperatures or damage may occur.

In the event that the 15m section of the power does coil on itself, it can easily be straightened by following the below instructions.

- Turn the power supply to the OFF position.
- Remove the cleaner from the pool and place it on the far end of the pool/yard area as shown in Fig 11.
- Unplug the 15m length of power cord from the power supply.
- Be sure to use a clear area that will allow the power cord to stretch out in a straight line.
- Hold the black collar at the plug end and gently lift the cable off the ground
- Gently pull on the cable and turn the cable with your fingers.
- The swivel will rotate as tension is applied, eliminating the coils in the cable.
- Return to normal cleaner use or store on Admiral ATV Caddy as shown in Fig C next page.

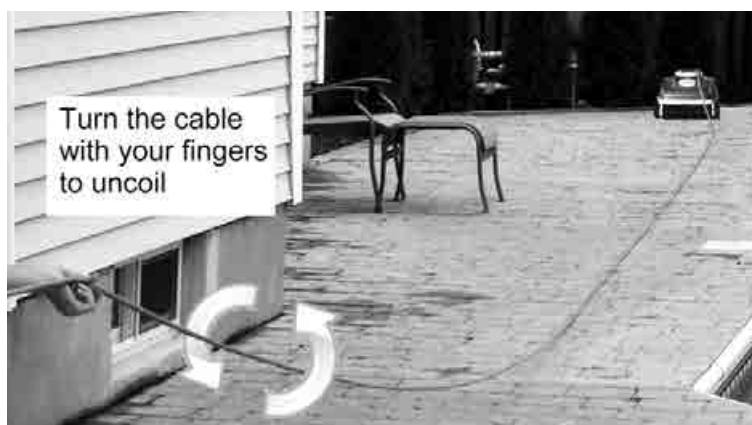

Figure 11

STORING THE BLUE POWER CORD

1. Unplug the power cord from the power supply.
2. Hold the power cord close to the cleaner. Refer Figure A.
3. Make a roughly half metre (two feet) loop with the power cord as shown. Refer Figure B.
4. When making loops, roll the power cord slightly in a counter clockwise manner to maintain form as shown in Fig C.

Note: Do not loop the power cord tightly around objects. Doing so may cause unnecessary stress to the power cord and floating swivel connections.

Note: When looping the power cord for storage it is best to start close to the cleaner rather than at the power connection end. Refer Figure A. Hold the power cord as close to the cleaner as possible and loop the power cord to the cleaner. Refer Figure B & C

Note: The Floating Swivel can remain connected to the 2.4m & 15m lengths of power cord during this process.

GENERAL MAINTENANCE GUIDE

To ensure the maximum life of the Admiral ATV, please follow the procedures below:

1. Clean The Admiral ATV's filter bag after every use.
2. Maintain a correct chemical balance of your pool/spa water. The chemical balance of water is a relationship between its pH, total alkalinity, calcium hardness and water temperature.

The water must be maintained at all times to the following:

PH LEVEL: BETWEEN 7.2 & 7.8.

TOTAL ALKALINITY: BETWEEN 80 & 150ppm.

CALCIUM HARDNESS: BETWEEN 150 & 300ppm.

Also, within these tolerances be balanced to the Langelier Saturation Index within a range of -0.2 to +0.2.

Note: Testing kits are available to test the water yourself or alternately bring a sample of the water to a professional pool and spa shop.

- Mains water and rural water supplies need to be monitored. Saturation (life) in mains water or bore (rural) will vary depending on water quality.

WINTER STORAGE

If temperatures will regularly be below 5°C (41°F) or over 45°C (113°F), the cleaner and power supply (transformer) should be stored indoors.



Figure A



Figure B



Figure C

WARRANTY

The Admiral ATV has been manufactured, tested and inspected in accordance with carefully specified engineering requirements. It is warranted to be free from defects in materials and workmanship under normal use and service, subject to qualifications, conditions and limitations described below.

2 Year Limited Warranty:

Two year full warranty, this includes drive motor and pump motor. This warranty applies only while using this product in Australia & New Zealand.

This warranty extends to the first consumer/purchaser for a period of 2 years from the original date of purchase.

This warranty covers only normal and reasonable use. Any damage, defects, malfunctions or other failures arising from its use without the original transformer or any use which does not comply with the instructions in this manual, including failure of the purchaser to provide reasonable and necessary maintenance, will void this warranty.

The warranty obligations of Waterco Ltd shall be limited to repair or replacement of the product or any defective component, at the discretion of Waterco Ltd. The repair or replacement may include the use of refurbished components and/or units. Waterco Ltd will not be liable or responsible under any circumstances or in any amount for any consequential or incidental damages, for any injury or damages to persons or property using or used in connection with this product, or for loss of profits or other costs or expenses of any kind or character.

This warranty does not include replacements of the filter bag, bottom lid, brushes and tracks..

CAUTION:

Some pool vinyl liners are more susceptible to surface wear and pattern removal than others, caused by objects such as brushes, toys, floats, chlorine dispensers, and automatic pool cleaners coming into contact with the pool vinyl surface.

Such patterns can be easily scratched or abraded merely by rubbing the surface with a brush. Pattern ink can also rub off when they come into contact with objects in the pool. Waterco Ltd is not responsible for, nor does this limited warranty cover pattern removal, abrasion, and markings on or damage to any kind of pool vinyl liner.

[Important note: you may have additional rights under warranties mandated by the Trade Practices Act or similar legislation].

PLEASE READ

1. These terms and conditions carefully, as failure to comply may affect your legal rights under this warranty; and
2. Any operation instructions carefully before commencing use of any product manufactured/Distributed by Waterco Limited ("Waterco").
Waterco manufactures quality pool and spa products to the highest standards using the most advanced technology and production procedures available.

WARRANTY COVER

If a defect occurs in any Waterco product during the warranty period, Waterco will at its discretion, repair the product or replace and install the defective part, free of charge provided that the defect results solely from poor workmanship or materials and subject to these terms and conditions.

Labour is covered by this warranty for a period of 2 years from the date of purchase or installation, within a 25 km (15 miles) radius of an authorised Waterco Service Agent.

The purchaser is responsible for any freight incurred.

Warranties are valid only within the original country of purchase. Our goods come with guarantees that cannot be excluded under the Australian Consumer Law [applicable only to Australian States and Territories]. You are entitled to a replacement or refund for a major failure and compensation for any other reasonably foreseeable loss or damage. You are also entitled to have the goods repaired or replaced if goods fail to be of acceptable quality and the failure does not amount to a major failure.

WARRANTY PERIOD

Waterco Admiral ATV Robotic Pool Cleaners are covered by a two year warranty.

All warranty periods commence on the date of purchase by the end user.

The provisions of this warranty are not transferable and are in addition to and not in modification of or subtraction from any applicable statutory warranties, rights or remedies.

WARRANTY PERIOD

This warranty only applies where:

1. The products requiring installation have been sold with installation included and have been installed by a licenced plumber, electrician or person who has completed an accredited course in swimming pool care and maintenance or a person with more than 1 year on the job learning or a person supervised by one of these people, in accordance with any written installation instructions provided.
2. The products have been installed and operated in accordance with written instructions supplied by Waterco;
3. The purchaser is able to provide proof of purchase that specifies the date of purchase;
4. The product has been serviced or maintained regularly. (at least once a month).
5. Any pool and spa equipment has been used in water:
 - a. With a temperature not exceeding 40 degrees Celsius;
 - b. With a pH range maintained between the pool water chemistry above mentioned 7.2 to 7.8;
 - c. That has been chemically balanced in accordance with the Langelier saturation index within a range of -0.2 to + 0.2 to ensure that it is not corrosive or scale forming;
 - d. That is not salt water (other than mild saline water conditions which are compatible with swimming pool salt water chlorination systems) – unless otherwise stated by Waterco in both the respective product labels and brochures that it is suitable for seawater applications; and
 - e. That has been regularly treated with a sanitising system using bromine, chlorine in one of its compound forms, or generated in-situ, in concentrations (doses) recommended by the relative state or territory health departments. (In areas outside of Australia please refer to the local health department recommendations before use);
6. Electrical equipment has been adequately protected from salt air environments and from salt water; and
7. All repairs and replacements shall be carried out by Waterco or its authorised service dealer, unless otherwise authorised in writing by Waterco.
8. If an authorised service dealer is not available within 25 km (15 miles) of the purchaser's area:
 - The purchaser must contact the place of purchase or Waterco for further instructions and;
 - The purchaser is responsible for any freight or infield labour costs.

EXCLUSIONS

This warranty does not cover, and Waterco will not be responsible for, any defect or damage caused or contributed to by:

- (a) installation or use of the product other than in accordance with Waterco's written instructions, any statutory requirements and these terms and conditions;
- (b) use of the product for a purpose other than for which it was designed or sold;
- (c) abuse, misuse, corrosion, internal and external, or normal wear and tear;
- (d) any repairs or modifications whatsoever carried out by any person, other than a Waterco authorised service dealer;

- (e) exposure to water not caused by a defect in the product; and
- (f) transit of the product over which Waterco has no control.
- (g) inadequate ventilation.
- (h) cement, pebbles, render or other pool surface finishes blocking the pump's impeller
- (i) insect and/or vermin infestation

To the extent permitted by law Waterco excludes all liability it may have to the purchaser for indirect, special or consequential loss arising from or related to any defect in any Waterco product, or any act or omission, including negligence of Waterco, including, but not limited to, loss of business, loss of profit, loss of revenue, lost opportunity, inconvenience, and damage to any property other than the Waterco product.

To the extent permitted by law, Waterco excludes all other conditions, guarantees, liabilities or representations that are not expressly set out in this agreement. These terms and conditions do not attempt to exclude, restrict or modify any applicable statutory rights, or any exercise of any statutory rights, or any liability imposed on Waterco by any law (including the Competition and Consumer Act 2010), if to do so would contravene that law or make any part of these terms and conditions void.

To the extent permitted by law, Waterco excludes all conditions and warranties implied into these terms and conditions and limits its liability for breach of any such condition or warranty that it cannot exclude to the greater of (at Waterco's option);

(a) for goods:

- Repairing or replacing those goods; or
- Paying the cost of having those goods repaired or replaced; and

(b) for services:

- Resupplying the services; or
- Paying the cost of having those services resupplied.

TEST YOUR WATER REGULARLY

The chemical balance of the water is a relationship between total alkalinity, pH, Calcium hardness and temperature. Waterco recommends that you have your water tested regularly by your local pool professional. A record of testing should always be kept for reference.

Some jurisdictions do not allow the exclusion or limitation of incidental or consequential damages, so any such limitation may not apply.

This warranty gives specific legal rights. The purchaser may have other rights depending on the jurisdiction in which the Waterco product was purchased or the purchaser is located.

Product	Warranty	Exclusions
Admiral ATV Robotic Pool Cleaner	2 Year	1. Leaving cleaner in direct sunlight & out of water 2. Human intervention damaging the cleaner 3. Normal wear & tear 4. Colour fading due to sun 5. Water chemistry out of normal range
Drive Motor and Pump Motor	2 Year	1. Human intervention damaging the cleaner 2. Water chemistry out of normal range
Filter bag, bottom lid, brushes & tracks	Excluded	3. Normal wear & tear component

Warranty Limitations:

The provisions of this warranty are not transferable from the original purchaser and are in addition to and not in modification of or subtraction from any applicable statutory warranties, rights or remedies.

Labour is covered by this warranty for a period of 2 years from the date of purchase or installation, within a 25 km (15 mile) radius of an authorised Waterco Service Agent.

Spare parts used in the repair of products are covered by a 2 year warranty and are not covered by the original warranty from date of purchase or installation.

The purchaser is responsible for any freight incurred.

NOTE:

Most pool cleaner problems are caused by incorrect installation, poor water chemistry and wear and tear. Please regularly check the condition of the Admiral ATV filter bag, bottom lid, brushes and tracks, as these are like the tyres on a car & need replacement from time to time.

Symptom	Possible Reasons
Cleaner Dead in water/Will not Restart	
Is time being allowed for the unit to reset?	At least 30 second are needed between cycles to reset the power supply.
Is the outlet working?	Earth Leakage Circuit Breaker or breaker may have tripped
Is an extension cord being used?	Extension cord may be defective
Are the connections to the swivel secure?	A loose connection may not allow for good electrical contact.
Cleaner not Moving	
Is there anything caught in the drive motor/brush/wheels area?	Debris could prevent the drive motor(s) from moving.
Is the bottom lid/filter bag installed correctly?	The bottom lid may be dragging on the pool surface.
Are the brushes spinning?	Drive motors may not be operational.
No Suction/Not Picking up Debris?	
Is the filter bag clean?	Large amounts of debris will reduce cleaner suction. (filter bag full)
Is there debris caught in the impeller?	Debris around the impeller may reduce cleaner suction.
Is the bottom lid/filter bag installed correctly?	An improperly installed filter bag may inhibit cleaner efficiency.
Is there water coming through the top of the cleaner?	The pump may not be operational.
Back and Forth in One Spot/Standing on End/Wheelies	
Is the bottom lid/filter bag installed correctly?	The bottom lid may be dragging on the pool surface.
Is there debris caught in wheels or brushes?	Debris may inhibit cleaner movement.
Is there enough cord in the pool?	The cleaner may not have enough cable for full pool coverage.
Spinning in One Spot	
Is there debris caught in the tracks, brushes or wheels?	Debris may inhibit cleaner movement.
Is the bottom lid/filter bag installed correctly?	The bottom lid may be dragging on the pool surface.
Are both drive motors rotating (NC7I)?	If one side of the drive motor isn't rotating then the unit will rotate in one area.
Cleaner floating	
Is there air caught in the filter bag?	Trapped air will cause the unit to float.
Is the filter bag clean?	Large amounts of debris will reduce cleaner suction.
Is there water coming through the top of the cleaner?	The pump may not be operational.
Is your pool depth greater than 2.4m?	The floating swivel may be lifting the cleaner slightly.
Cleaner Not Climbing	
Is there algae present in water?	Algae will create slick surfaces.
Are the brushes worn?	Wear and tear on brushes or tracks will reduce traction.
Is the filter bag clean?	Large amounts of debris will reduce cleaner suction.
Is there water coming through the top of the cleaner?	The pump may not be operational.
Power Cord Tangling	
How much power cord is in the pool?	Too much power cord in the pool will increase chances for cable tangling.
Is the power cord being unplugged after every cycle?	Tension will build in the power cord during the cleaning cycle.
Are there objects in the pool?	Toys/floats/pool rope lines may cause the power cord to tangle.
Cleaner Trapped on Steps	
Is there air caught in the filter bag?	Trapped air will cause the unit to float.
Has the pool water level gone down?	Water levels may have changed and the unit may be taking in air.

TROUBLESHOOTING

Potential Solution
Turn power supply off and allow 30 seconds for cleaner to reset.
Check Earth Leakage Circuit Breaker or breaker and try a different outlet.
Try running the cleaner without an extension cord. Using a Electrical Extension cord is not recommended.
Remove the cleaner from the pool and check all power cord/floating swivel connections.
Check for debris and remove if found.
Make sure the filter bag/bottom lid is properly installed or test cleaner without bottom lid. (Red Clips)
Check to see if the brushes are rotating during the cleaning cycle.
Thoroughly rinse the filter bag. Dirty pools may require the bag to be cleaned part way through cycle.
Check for debris and remove if found.
Make sure the filter bag is correctly installed ("PUSH IN" label should be covered by tab on bottom lid).
Check to see if there is water coming through the impeller during operation.
Make sure the filter bag/bottom lid is properly installed or test cleaner without bottom lid. (Red Clips)
Check for debris and remove if found.
Make sure enough cable is in the pool to cover all areas.
Check for debris and remove if found.
Make sure the filter bag/bottom lid is properly installed or test cleaner without bottom lid. (Red Clips)
Check to see if the brushes are rotating during the cleaning cycle.
Hold the cleaner under water and rock back and forth before starting the cycle.
Thoroughly rinse the filter bag. Dirty pools may require the bag to be cleaned part way through cycle.
Check to see if there is water coming through the impeller during operation.
The maximum depth of a swimming pool for proper operation of an Admiral ATV is 2.4m.
Brush walls and check water chemistry.
Replace worn brushes or tracks.
Thoroughly rinse the filter bag. Dirty pools may require the bag to be cleaned part way through cycle.
Check to see if there is water coming through the impeller during operation.
Only allow enough power cord in the pool for the cleaner to have full coverage.
Make sure to unplug the power cord from the power supply frequently to reduce risk of cable tangling.
Remove any obstructions from the pool to prevent the power cord from becoming entangled.
Hold the cleaner under water and rock back and forth before starting the cycle.
Hold the cleaner on the steps (while off) and see if the top of the unit is above the water line.

OFFICES - AUSTRALIA

NSW - SYDNEY (HEAD OFFICE)
Tel: +61 2 9898 8600

QLD - BRISBANE
Tel: +61 7 3299 9900

VIC/TAS - MELBOURNE
Tel: +61 3 9764 1211

WA - PERTH
Tel: +61 8 9273 1900

SA/NT - ADELAIDE
Tel: +61 8 8244 6000

ACT DISTRIBUTION
Tel: +61 2 6280 6476

OFFICES - OVERSEAS

WATERCO (EUROPE) LIMITED
Sittingbourne, Kent, UK
Tel: +44 (0) 1795 521 733

WATERCO FRANCE
Saint Priest, France
Tel: +33 4 72 79 33 30

WATERCO (USA) INC
Augusta, Georgia, USA
Tel: +1 706 793 7291

WATERCO CANADA
Longueuil, Quebec, Canada
Tel: +1 450 748 1421

WATERCO (NZ) LIMITED
Auckland, New Zealand
Tel: +64 9 525 7570

WATERCO © LIMITED
Guangzhou, China
Tel: +86 20 3222 2180

WATERCO (FAR EAST) SDN BHD
Selangor, Malaysia
Tel: +60 3 6145 6000

PT WATERCO INDONESIA
Jakarta, Indonesia
Tel: +62 21 4585 1481

WATERCO SINGAPORE INTL PTE LTD
Nehsons Building, Singapore
Tel: +65 6344 2378